



AC5295

XP95 Optical Smoke Detector

Operation

The XP95 Optical Smoke Detector uses the same outer case as the ionisation smoke detector and is distinguished by the indicator LED which is clear in standby and red in alarm. Within the case is a printed circuit board which on one side has the light proof labyrinth chamber with integral gauze surrounding the optical measuring system and on the other the address capture, signal processing and communications electronics.

An infrared light emitting diode within its collimator is arranged at an obtuse angle to the photo-diode. The photo-diode has an integral daylight blocking filter.

The infrared LED emits a burst of collimated light every second. In clear air the photo-diode receives no light directly from the infrared LED because of the angular arrangement and the dual mask. When smoke enters the chamber it scatters photons from the emitter infrared LED onto the photo-diode in an amount related to the smoke characteristics and density. The photo-diode signal is processed by the optical ASIC and passed to the A/D converter on the communications ASIC ready for transmission when the device is interrogated.

Electrical description

The XP95 Optical Smoke Detector is designed to be connected to a two wire loop circuit carrying both data and a 17 V to 28 V dc supply. The detector is connected to the incoming and outgoing supply via terminals L1 and L2 in the mounting base. A remote LED indicator requiring not more than 4 mA at 5 V may be connected between the +R and -R terminals. An earth connection terminal is also provided. The detector is calibrated to give an analogue value of 25±7 counts in clean air. This value increases with smoke density. A count of 55 corresponds to the EN 54 alarm sensitivity level.

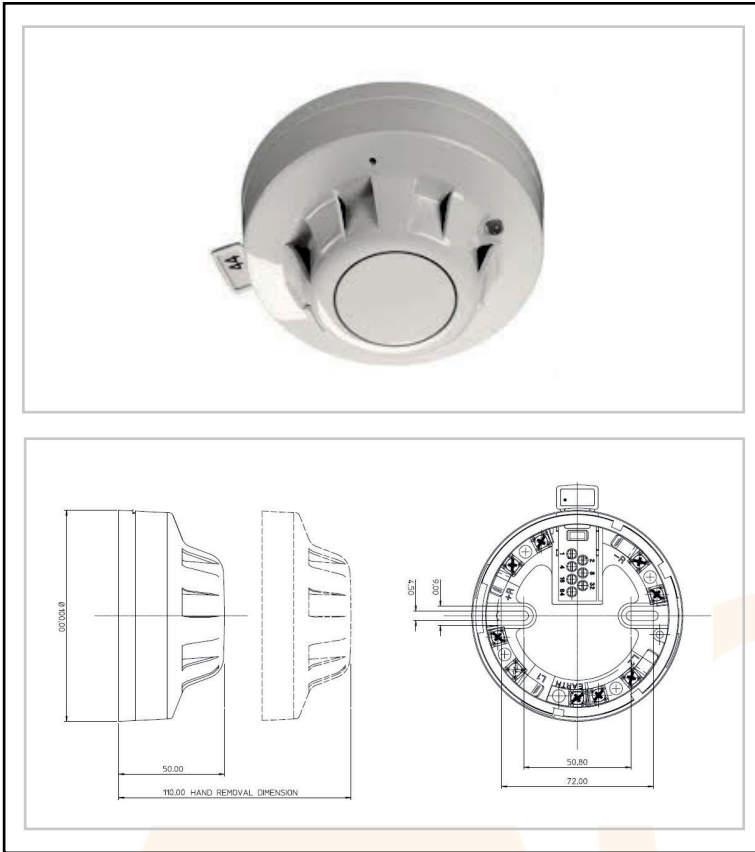

Technical Specification

Dimensions	Diameter 100 mm Depth 42mm
Operating Temperature	-12°C to +60° C
Voltage Range	17-28V DC from panel
Operating current	Quiescent 340 uA
Detection Principal	Photo electrical detection of scattered light
Sampling Frequency	Once per second
Digital Comms	XP95, Discovery & Core Protocol
Supply Wiring	2 wire supply- polarity insensitive
Weight	105gm

5-AC5295-2022-V1